

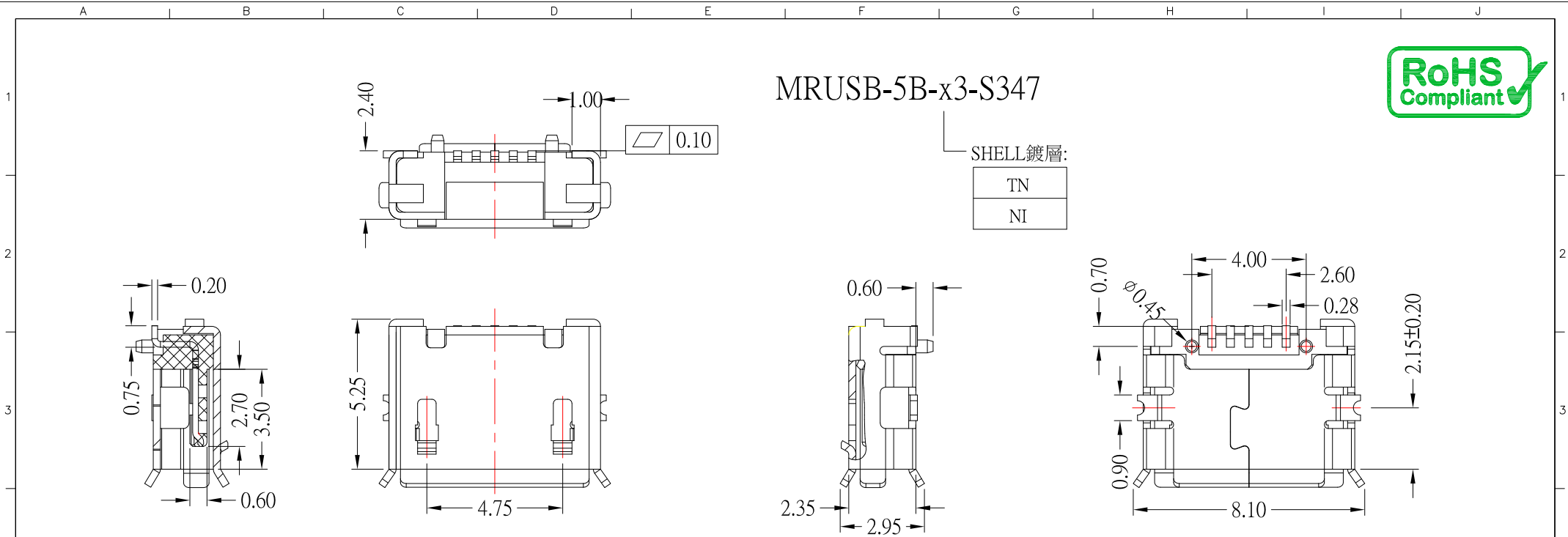

# MRUSB-5B-x3-S347



SHELL 鍍層:

TN
NI

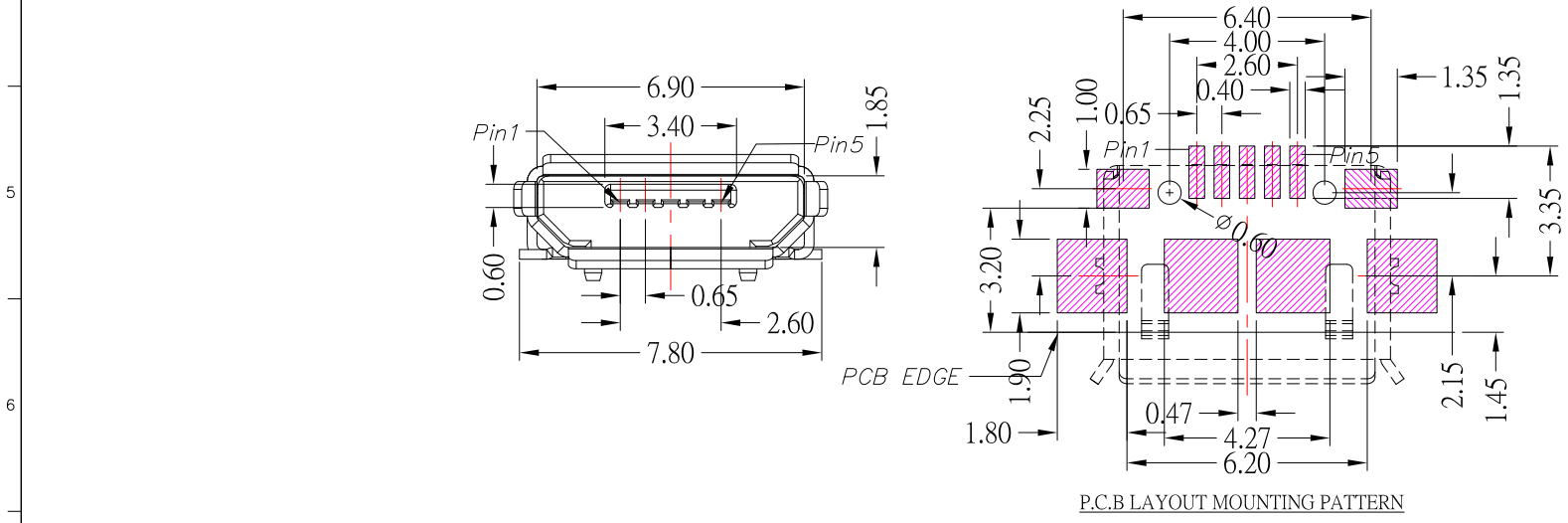

NOTES:  
 MATERIAL:  
 1.1 HOUSING: LCP  
 1.2 CONTACT: PHOSPHOR BRONZE  
 1.3 SHELL: BRASS  
 Finish:  
 2.1 Contact: Plated Gold in Mating Area ;  
 Gold Plated on Solder Balls  
 Nickel under plated overall  
 2.2 Shell: Nickel or Tin under Plated surface layer  
 3.SPECIFICATION:  
 3.1 CURRENT RATING: 1.8 A MAX(PIN1,5) ; 1.0 A MAX(PIN2,3,4)  
 3.2 DIELECTRIC WITHSTANDING VOLTAGE: 100 V(ac) FOR 1min  
 3.3 CONTACT RESISTANCE: 30 mΩ MAX.  
 3.4 INSULATION RESISTANCE: 100 MΩ MIN.  
 3.5 TOTAL MATING FORCE: 3.57 Kgf MAX.  
 3.6 TOTAL UNMATING FORCE: 1.0 Kgf MIN.  
 3.7 TEMPERATURE RANGE: -30°C ~ +80°C

5	更新樣式	Lan	041819
4	更新圖面	Jack	122017
3	新增尺寸	Jack	092217
2	更新圖面	Jack	051817
1	更新為A0版	Jack	111016
ITEM NO.	DESCRIPTION	DRAWN	DATE

**東莞市高迪電子有限公司**  
**DONG GUAN GAO DI ELECTRONICS CO., LTD**

TOLERANCE UNLESS OTHERWISE STATED:  
 Up to 5 ±0.2  
 Above 5 ~ 15 ±0.3  
 Above 15 ~ 30 ±0.4  
 Above 30 ~ 50 ±0.5  
 Angle ±0.3°

3RD. ANGEL'S

UNITS MM

DRAWN BY:	DATE	MAT'L	TITLE	CONNECTOR
Jack Lu	04/18/19		MODLE	MICRO USB 5B/F 全貼有柱
CHECKED BY:	DATE	FINISH	DWG NO.	MRUSB-5B-x3-S347
Jacky Chen	04/18/19	SCALE	1 : 1	PART NO. MRUSB-5B-x3-S347
APPROVED BY:	DATE	SHEET NO.	1 of 1	
Tony Kao	04/18/19			
				SIZE A4
				VER R5